

Vickers®

Directional Controls



Mechanical Actuators Directional Control Valves

DG2S2/4-01*-52 Plunger Operated
DG16S2/4-01*-52 Deceleration Valve
DG1S2/4-01*-50 Knob Operated
DG17S2/4-01*-50 Lever Operated
NFPA D05, ISO-4401-05

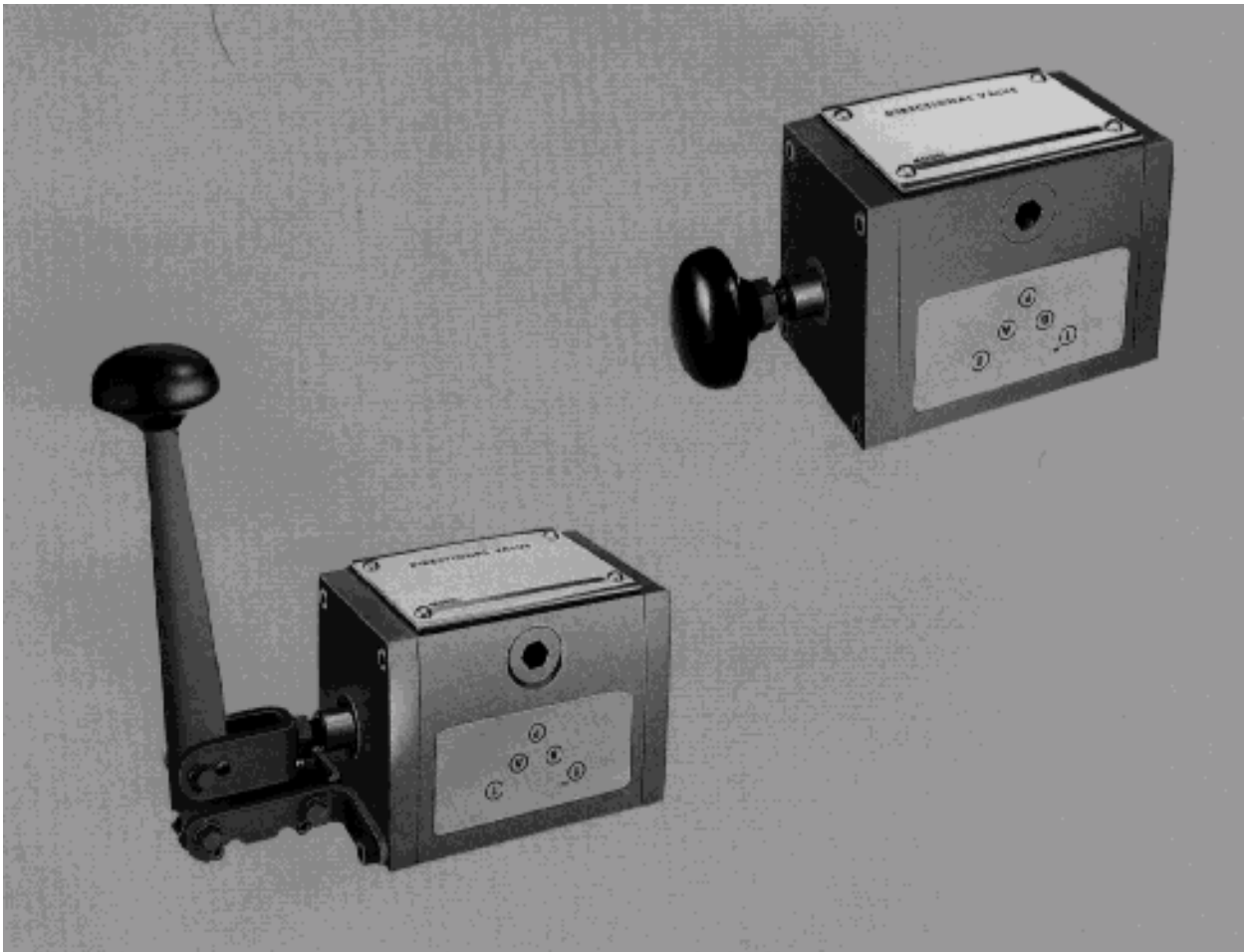
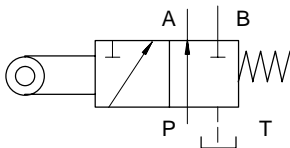

Table of Contents

DG2/16S2/4-01-52 Model Code Specifications	4
Pressure Drop	5
DG2/16S2/4-01 Installation Dimensions	6
DG(1)7S2/4-01-50 Model Code	7
General Information	8
Basic Characteristics	
Mounting Interface	
Shifting Action	
Mounting Position	
Installation Data	
Service Information	
Pressure Drop	
DG1S2/4-01 Installation Dimensions	9
DG1S4-01 Installation Dimensions	10
DG17S2/4-01 Installation Dimensions	11
DG17S4-01 Installation Dimensions Specifications	12
Subplates & Bolt Kits	14
Application Data	15

Functional Symbols

Spring offset - Two-way
(mechanically operated)



Model DG2S2-012A-52

Spring offset - Four-way
(mechanically operated)

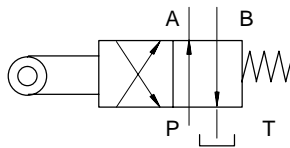

Model DG2S4-012A-52

Spring offset - Deceleration
(mechanically operated)

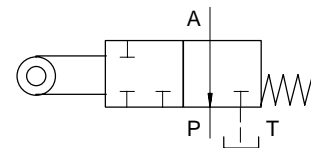

Model DG16S2-010A-52

Introduction

General Description

The mechanical directional control valves described in this brochure are:

- Two & Four-way cam operated valves
DG2/16S4-01
- Knob & Lever operated valves
DG1/17S4-01

Mechanical operation used by these valves is achieved by either hand actuation or roller cam. Many applications that use the roller cam feature are deceleration valves to control the movement of a load.

The DG2 two and four-way directional valves may be used for a wide range of applications where mechanical actuation is preferred.

The DG16 deceleration valve provides an ideal method of hydraulically controlling deceleration through mechanical actuation. An outstanding feature of this valve is its smooth deceleration capability for low flows.

DG1 and DG17 are manual knob and lever operated valves used for applications requiring two and four-way directional operation. The two-way valves are available in both spring offset and no-spring detented versions. The four-way valves are offered in spring offset, spring centered and no-spring detented versions.

Basic Characteristics

Max. pressure: 207 bar (3000 psi)
Max. flow: 75,7 l/min (20 USgpm)
Max. pressure port T:
..... 69 bar (1000 psi)
Weight: 3,6 kg (8 lbs.)
Fluid Cleanliness - See page 13.
Mounting Subplate - 2,07 kg (4.5 lbs)

Mounting Interface

ISO 4401-05
CETOP 5
NFPA D05

Mounting Position

Valves are spring offset and have no restrictions as to mounting position.

Installation Data

Drain connection must be piped directly to tank through a surge free line so there will be no back pressure at this port.

Maximum cam angle
recommended 35°

NOTE

Any sliding spool valve, if held for long periods of time, may stick and not spring return due to fluid residue formation and therefore, should be cycled periodically to prevent this from happening.

Service Information

Refer to specific Vickers parts drawing for service parts information. A complete parts breakdown is contained in this drawing.

Order by literature number.

DG2S2/4-01-52 I-3572-S
DG16S2-01-52 I-3572-S
DG1S2-012(A)-50 I-3546-S
DG1S4/2S2-01-50 I-3546-S

Model Code

Deceleration, Two & Four-way Directional Valves

D G * S *-01 * A- 52 - LH

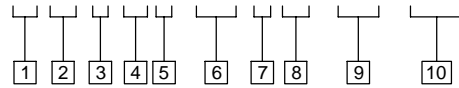

1 Directional control	5 Flow direction 2 - Two-way 4 - Four-way (not available on DG16)	8 Spool/Spring arrangement A - Spring offset
2 Mounting type G - Manifold or Subplate	6 Valve size 01 - ISO-4401-05, NFPA-D05 interface	9 Design number Subject to change. Installation dimensions remain as shown for design numbers 50 through 59.
3 Valve type 2 - Mechanically operated 16 - Non-adjustable deceleration	7 Spool type (crossover condition) 0 - Open center (DG16S2 only) 2 - Closed center (DG2S2 only) 6 - Closed center, P only 7 - Closed center, T blocked 33 - Closed center, bleed A & B	10 Left hand LH - Plunger assembled in the B port end of valve. Right hand models shown.
4 Sliding spool		

Specifications

Model Numbers		Max. Flow l/min (USgpm)		Actuation force under no-flow conditions approx. kg (lbs) max.	Valve Type	Direction of oil flow for valve spool position	
Mechanical Directional	Mechanical Deceleration	69 bar (1000 psi)	207 bar (3000 psi)			Extended	Depressed
DG2S2-012A-52	–	45,4 (12)	30,3 (8)	8,6 (19)	2-way	P → A B blocked	P → B A blocked
DG2S4-012A-52	–	75,7 (20)	75,7 (20)	8,6 (19)	4-way	P → A B → T	P → B A → T
–	DG16S2-010A-52	45,4 (12)	30,3 (8)	8,6 (19)	Decel.	A → P	A blocked

→ Full flow

Pressure Drop

Pressure Drop DG2S4

Spool Type	P to A	B to T	P to B	A to T	P to T Centered	Recommended Flow
0	1,9 bar (28 psi)	1,7 bar (24 psi)	1,9 bar (28 psi)	2,3 bar (33 psi)	2,3 bar (33 psi)	37,9 l/min (10 USgpm)
2	2,1 bar (31 psi)	2,4 bar (35 psi)	2,1 bar (31 psi)	2,8 bar (40 psi)	—	
6	2,1 bar (31 psi)	1,7 bar (24 psi)	2,1 bar (31 psi)	2,3 bar (33 psi)	—	
7	1,9 bar (28 psi)	2,3 bar (33 psi)	1,9 bar (28 psi)	2,8 bar (40 psi)	—	
33	2,1 bar (31 psi)	2,3 bar (33 psi)	2,1 bar (31 psi)	2,8 bar (40 psi)	—	

Pressure Drop DG2S2/4 & DG16S2

Model Number	Valve Type	P to A	B to T	P to B	A to T	A to P	Recommended Flow
DG2S2-012A-52	Two-way	1,4 bar (20 psi)	—	1,4 bar (20 psi)	—	—	37,9 l/min (10 USgpm)
DG2S4-012A-52	Four-way	1,4 bar (20 psi)	1,6 bar (23 psi)	1,4 bar (20 psi)	1,8 bar (26 psi)	—	
DG16S2-010A-52	Deceleration	—	—	—	—	3,4 bar* (50 psi)	

* Full open position

- Figures in the pressure drop chart give approximate pressure drops (ΔP) when passing 38 l/min (10 USgpm) flow (Q) of 100 SUS fluid(s) having .865 specific gravity.
- For any other flow rate (Q_1), the pressure drop (ΔP_1) will be approximately:

$$\Delta P_1 = \Delta P(Q_1/Q_2)^2$$
- For any other viscosity(s), the pressure drop (ΔP) will change as follows:

Viscosity	14	32	43	54	65	76	86
cSt	14	32	43	54	65	76	86
(SUS)	(75)	(150)	(200)	(250)	(300)	(350)	(400)
% of ΔP (Approx.)	93	111	119	126	132	137	141

- For any other specific gravity (G_1)**, the pressure drop (ΔA_1), will be approximately:

$$\Delta P_1 = \Delta P(G_1/G)$$

** Specific gravity of fluid may be obtained from its producer. The value is higher for fire-resistant fluids than for oil.

Pressure vs. Spool Position

Deceleration valve DG16S2-01A-52
30 l/min (8 USgpm) Flow - 100 SUS fluid

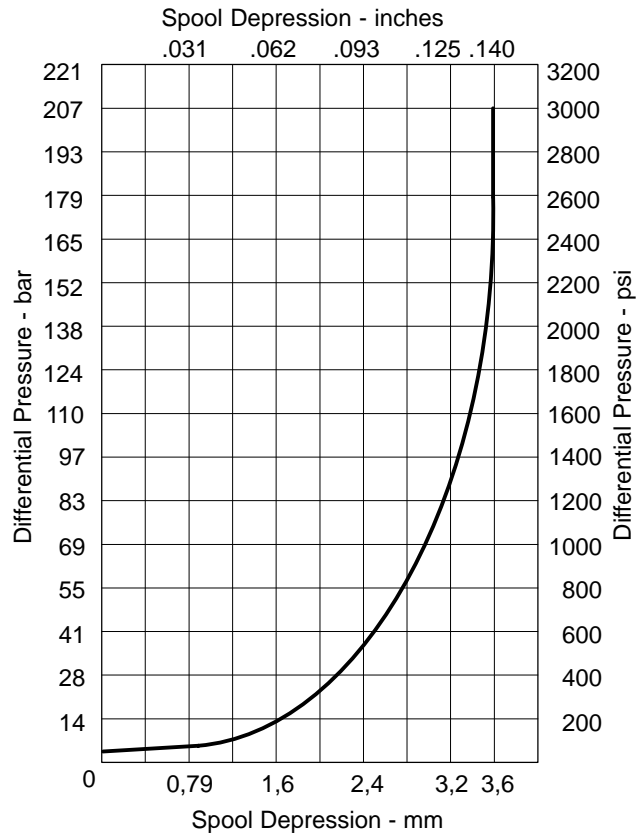

Installation Dimensions

Mechanically Operated 2-way, 4-way & Deceleration Valves Spring Offset

mm (inches)

DG2S2
DG2S4
DG16S2

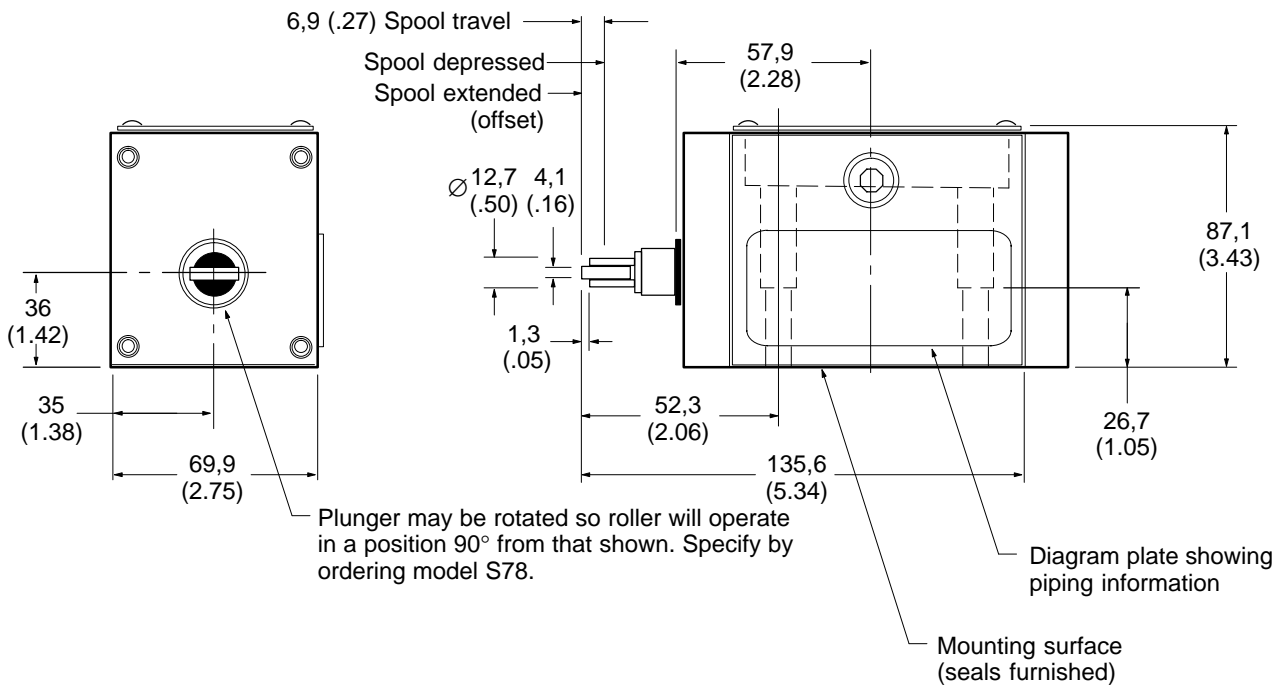
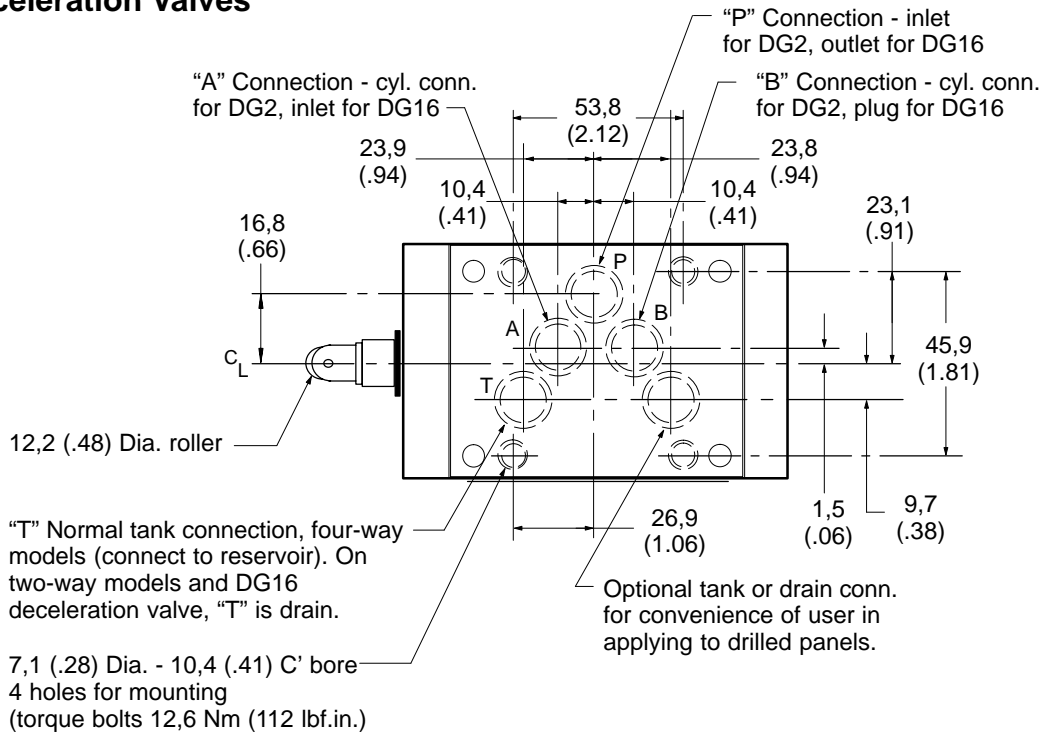

Model Code

Knob & Lever Operated Directional Valves

D G * S * - 01 2 A - 50 - LH

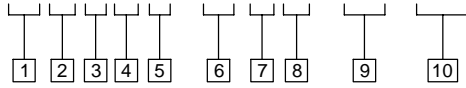

1 Directional control

2 Mounting type

G - Manifold or Subplate

3 Valve operator

1 - Manual knob operated
17 - Manual lever operated

4 Sliding spool

5 Flow direction

2 - Two-way
4 - Four-way - spring offset model only

6 Valve size

01 - ISO-4401-05, NFPA-D05 interface

7 Spool type (center condition)

0 - Open center
2 - Closed center
3 - Closed center, P & B
6 - Closed center, P only
7 - Closed center, T blocked
8 - Tandem crossover
33 - Closed center, bleed A & B

8 Spool/Spring arrangement

A - Two-position, spring offset
C - Three position, spring centered
N - Three position, detented

9 Design number

Subject to change. Installation dimensions remain as shown for design numbers 50 through 59.

10 Left hand

Knob or lever on B end. (Reversed from A port end models shown.)

Functional Symbols

Spring offset - Two-way

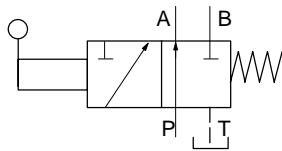

Model DG1S2-012A-50
Model DG17S2-012A-50

No-spring - Two-way
Detented

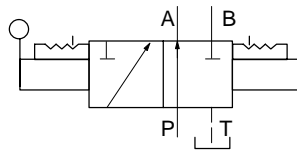

Model DG1S2-012N-50
Model DG17S2-012N-50

Spring offset - Four-way

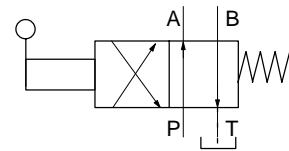

Model DG1S4-012A-50
Model DG17S4-012A-50

Spring centered - C

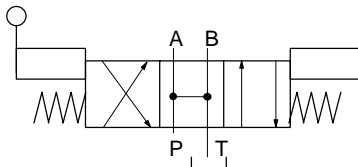

Model DG17S4-010C-50

No-spring - Detented N

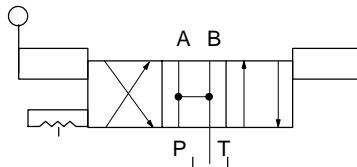

Model DG17S4-010N-50

General Information

Basic Characteristics

Max. pressure: 207 bar (3000 psi)
 Max. flow: 75,7 l/min (20 USgpm)
 Max. pressure port T: 69 bar (1000 psi)
 Weights:
 DG1 knob operated: 3,4 kg (7.5 lbs.)
 DG17 lever operated: 4,0 kg (9 lbs.)
 Subplate: 2 kg (4.5 lbs.)
 Fluid Cleanliness - See page 13.

Mounting Interface

ISO 4401-05
 CETOP 5
 NFPA D05

Shifting Action

Spring offset valves are spring positioned unless lever is actuated. No-spring detented valves maintain the spool position last selected. Machine vibration, heat, improper circuitry and externally induced shocks may cause no-spring detented valves to shift prematurely.

Spring centered valves return the spool to center position when the lever or knob control is released.

No-spring detented valves will remain in the last position attained provided there is no severe shock, vibration or unusual pressure transients.

CAUTION

Surges of oil in a common tank line serving these and other valves can be of sufficient magnitude to cause inadvertent shifting of these valves. This is particularly critical in the no-spring detented type valves. Separate tank lines or a vented manifold with a continuous downward path to tank is necessary.

Mounting Position

No-spring detented valves must be installed with the longitudinal axis horizontal for good machine reliability.

The mounting position of spring-offset models is unrestricted.

Installation Data

Drain connection must be piped directly to tank through a surge-free line so there will be no back pressure at this port.

NOTE

Any sliding spool valve, if held for long periods of time, may stick and not spring return due to fluid residue formation and therefore, should be cycled periodically to prevent this from happening.

Service Information

Refer to specific Vickers parts drawing for service parts information. A complete parts breakdown is contained in this drawing.
 Order by literature number.
 DG1S2/4-01-50 I-3546-S
 DG17S2-01-50 I-3546-S

Pressure Drop DG(1)7S*

Spool Type	P to A	B to T	P to B	A to T	P to T Centered	Recommended Flow
0	1,9 bar (28 psi)	1,7 bar (24 psi)	1,9 bar (28 psi)	2,3 bar (33 psi)	2,3 bar (33 psi)	37,9 l/min (10 USgpm)
2	2,1 bar (31 psi)	2,4 bar (35 psi)	2,1 bar (31 psi)	2,8 bar (40 psi)	—	
3	2,1 bar (31 psi)	2,4 bar (35 psi)	2,1 bar (31 psi)	2,3 bar (33 psi)	—	
6	2,1 bar (31 psi)	1,7 bar (24 psi)	2,1 bar (31 psi)	2,3 bar (33 psi)	—	
7	1,9 bar (28 psi)	2,3 bar (33 psi)	1,9 bar (28 psi)	2,8 bar (40 psi)	—	
8	1,4 bar (21 psi)	1,6 bar (24 psi)	1,4 bar (21 psi)	1,9 bar (28 psi)	4,5 bar (65 psi)	30 l/min (8 USgpm)
33	2,1 bar (31 psi)	2,3 bar (33 psi)	2,1 bar (31 psi)	2,8 bar (40 psi)	—	37,9 l/min (10 USgpm)

1. Figures in the pressure drop chart give approximate pressure drops (ΔP) when passing 38 l/min (10 USgpm) flow (Q) of 100 SUS fluid(s) having .865 specific gravity.

2. For any other flow rate (Q_1), the pressure drop (ΔP_1) will be approximately:

$$\Delta P_1 = \Delta P(Q_1/Q_2)^2$$

3. For any other viscosity(s), the pressure drop (ΔP) will change as follows:

Viscosity	14	32	43	54	65	76	86
cSt	14	32	43	54	65	76	86
(SUS)	(75)	(150)	(200)	(250)	(300)	(350)	(400)

% of ΔP (Approx.) 93 111 119 126 132 137 141

4. For any other specific gravity (G_1)*, the pressure drop (ΔA_1), will be approximately:

$$\Delta P_1 = \Delta P(G_1/G)$$

* Specific gravity of fluid may be obtained from its producer. The value is higher for fire-resistant fluids than for oil.

Installation Dimensions

Two-way, Four-way & Knob Operated Spring Offset & No-Spring

Millimeters (inches)

DG1S2-C
DG1S4-C

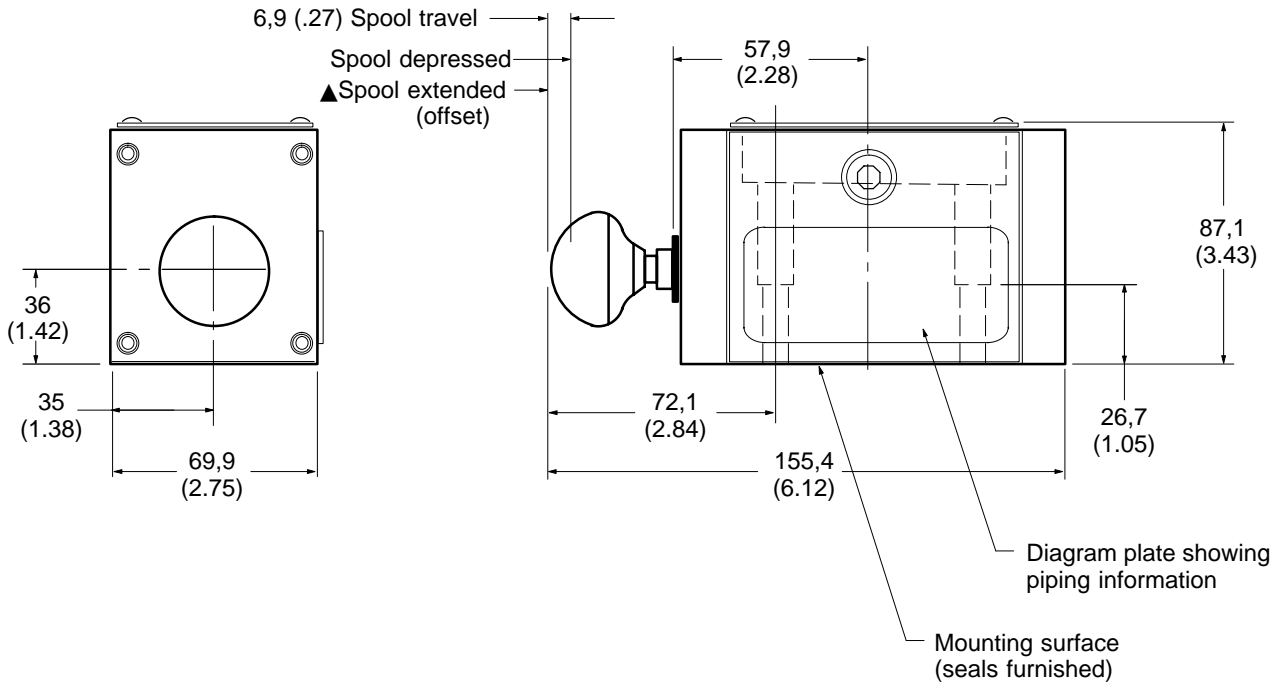
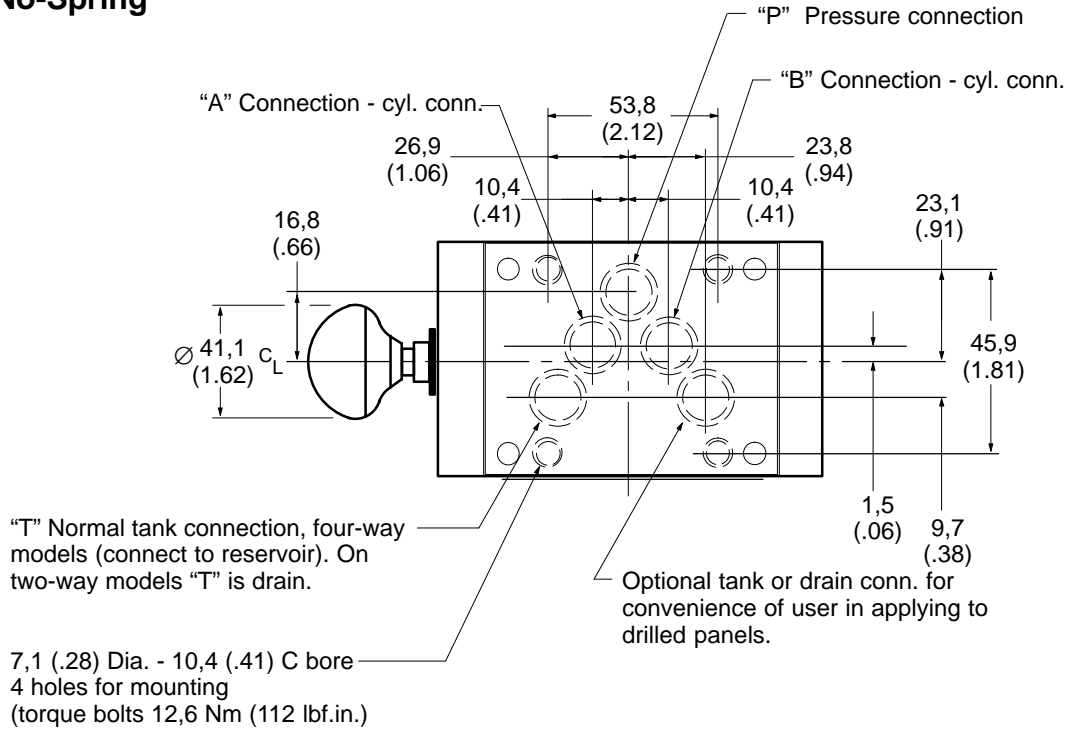

▲ See no-spring detented symbol. Center not used.

Installation Dimensions

No-Spring Detented & Spring Centered Manual Knob Operated Valve

Millimeters (inches)

DG1S4-01 C/N

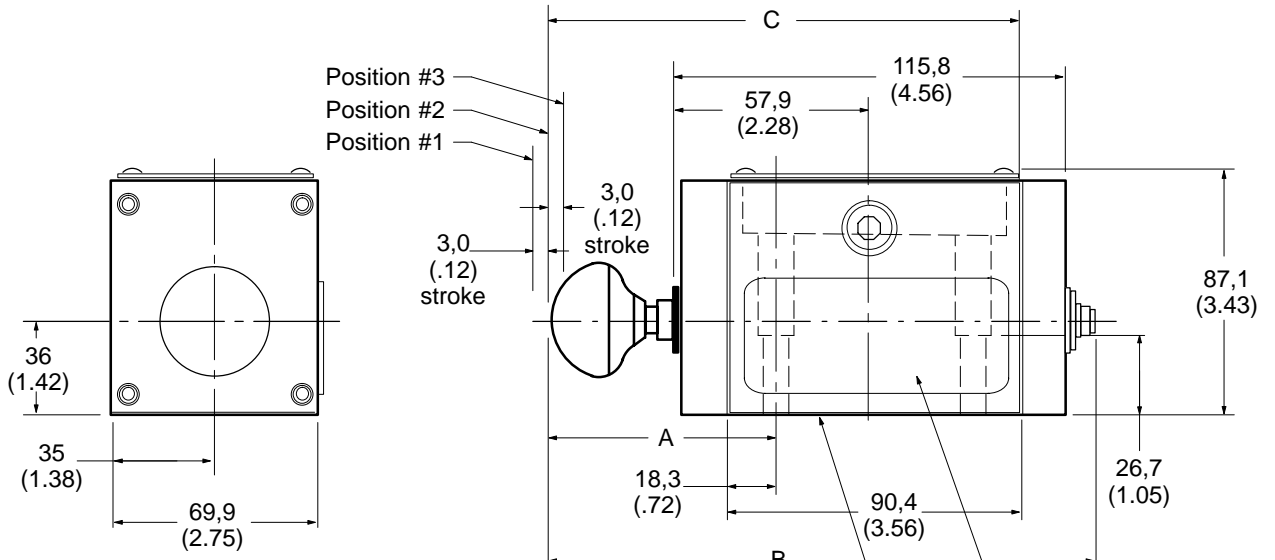
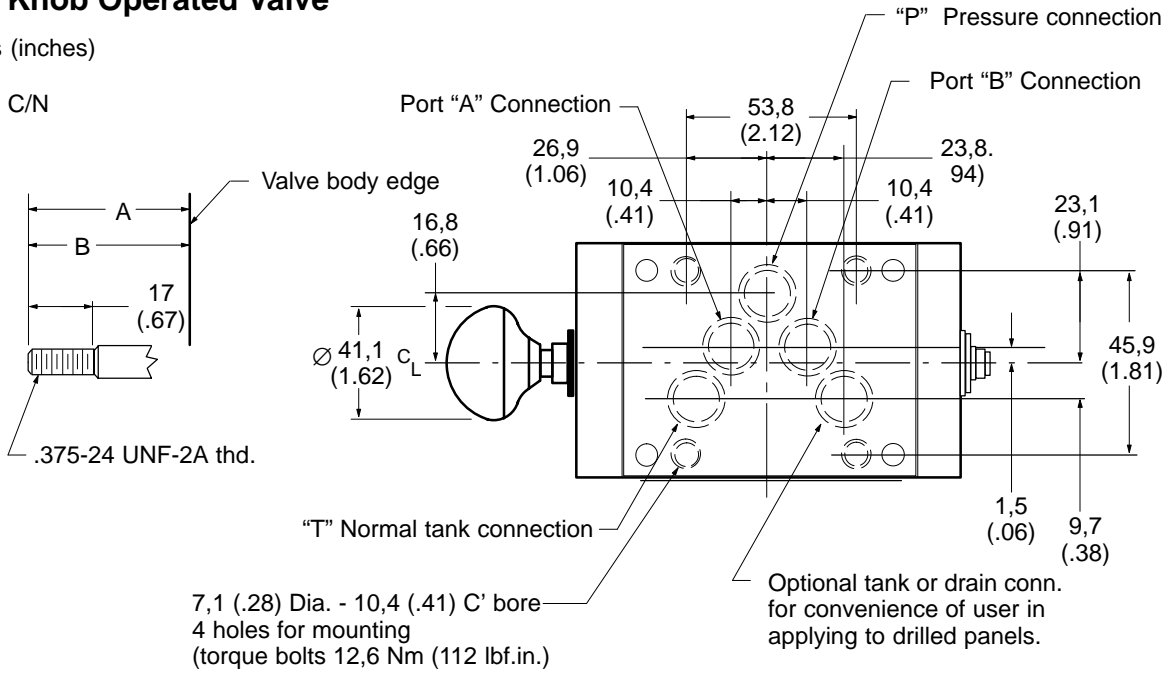

Spool Type	Dimension		
	A	B	C
0, 2, 3, 6, 7 & 33	69,1 (2.72)	159 (6.26)	153,9 (6.06)
Type 8	73,9 (2.91)	168,6 (6.64)	158,7 (6.25)
Stem - without knob			
0, 2, 3, 6, 7 & 33	56,4 (2.22)	146,3 (5.76)	141,2 (5.56)
Type 8	61,2 (2.41)	155,6 (6.14)	146 (5.75)

Installation Dimensions

Spring Offset & No-Spring Manual Lever Operated Valves

Millimeters (inches)

DG17S2 A
DG17S4 A

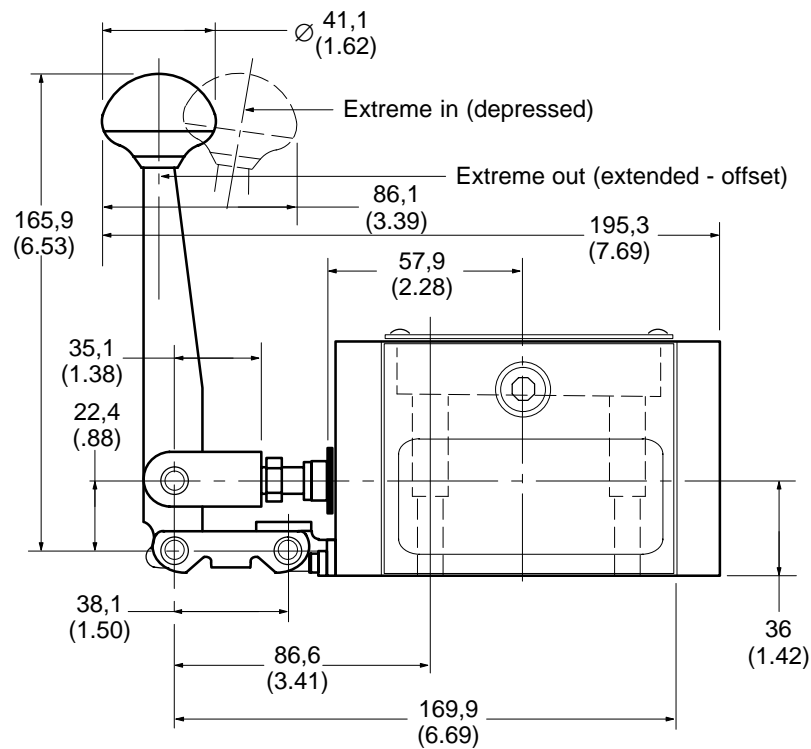

Specifications

Model Numbers		Valve Type	Max. Flow l/min (USgpm)		Direction of oil flow for valve spool position		Recommended Flow l/min (USgpm)
Manual Operator w/knob	Manual Operator w/ lever		at 69 bar (1000 psi)	at 207 bar (3000 psi)	Extended	Depressed	
DG1S2-012N-50	DG17S2-012N-50	2-way	75,7 (20)	56,8 (15)	P → A B blocked	P → A A blocked	37,9 (10)
DG1S2-012A-50			75,7 (20)	56,8 (15)			
DG17S2-012A-50			30,3 (8)	18,9 (5)			
DG17S2-012A-50			45,4 (12)	30,3 (8)			
DG1S4-012A-50	DG17S4-012A-50	4-way	30,3 (8)	18,9 (5)	P → A B → T	P → B A → T	
DG17S4-012A-50			75,7 (20)	75,7 (20)			

→ Full flow

Installation Dimensions

Spring Centered & No-Spring Detented Manual Lever Operated Valves

Millimeters (inches)

DG17S4-01-C/N

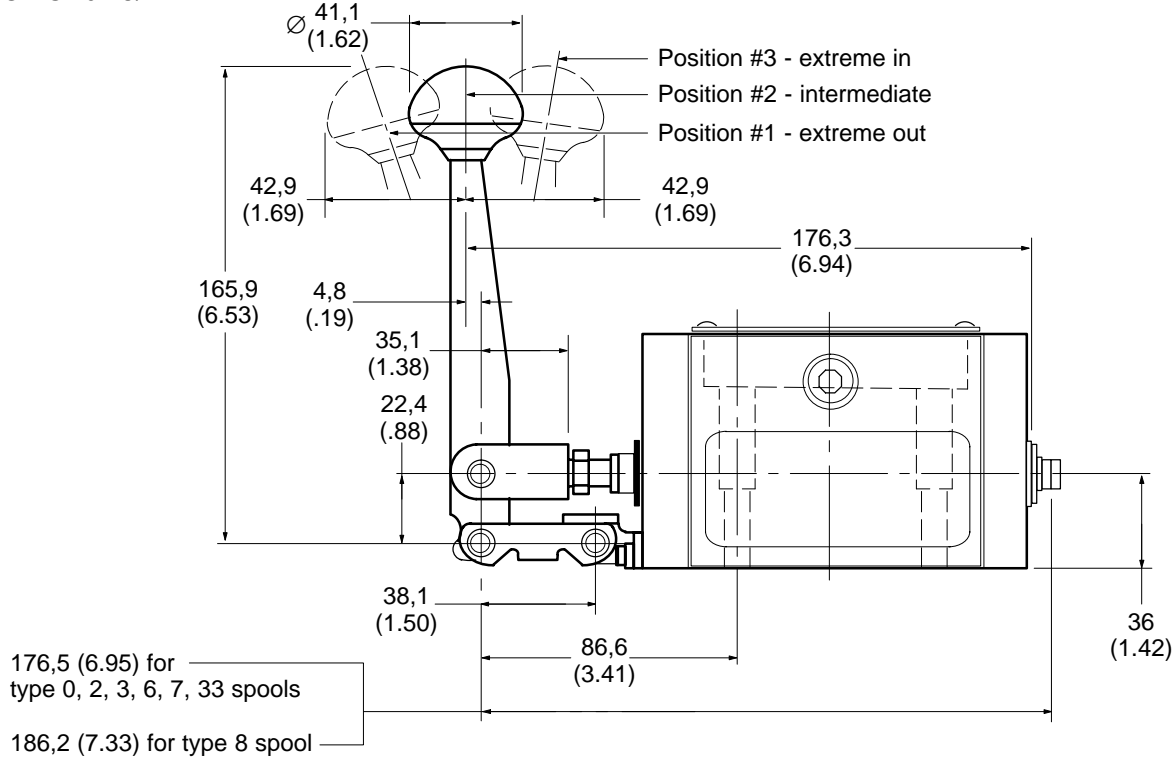

Specifications

Model Numbers		Spool Type	Direction of oil flow for valve spool position			Rec. Flow l/min (USgpm)	Max Flow l/min (USgpm)	
Manual Operator w/knob	Manual Operator w/ lever		With spool in center pos. #2	Pos. #1	Pos. #3		69 bar (1000 psi)	207 bar (3000 psi)
DG1S4-010*-50	DG17S4-010*-50	0 - Open center all ports	Fully open					
DG1S4-012*-50	DG17S4-012*-50	2 - Closed center all ports	Fully closed					
DG1S4-013*-50	DG17S4-013*-50	3 - Closed center P and B	P & B blocked A → T	P → A B → T	P → B A → T	37,9 (10)	30,3 (8)	18,9 (5)
DG1S4-016*-50	DG17S4-016*-50	6 - Closed center P only	P blocked A & B → T					
DG1S4-017*-50	DG17S4-017*-50	7 - Open center T blocked	P → A & B T blocked					
DG1S4-0133*-50	DG17S4-0133*-50	33 - Closed center Bleed A & B	P blocked A & B ↘ → T					
	DG17S4-018*-50	8 - Open center P to T	P to T A & B blocked	P → B A → T	P → A B → T	30,3 (8)	45,4 (12)	45,4 (12)

→ Full flow

↘ Restricted flow

Subplates & Bolt Kits

Valves, subplates and mounting bolts must be ordered separately.

Example:

- One (1) DG**S4-012A-5* Valve
- One (1) DGSM(E)-01-20-T8 Subplate
- One (1) BKDG01-633 Bolt Kit

When subplate is not used, a machined pad must be provided for mounting. Pad must be flat within 0,0127 mm (.0005 inch) and smooth within 63 microinch. Mounting bolts, when provided by customer, should be SAE grade 7 or better.

Torque mounting bolts to:
13 Nm (115 lb. in.)

Mounting Subplate DGSM-01-20-T8

Millimeters (inches)

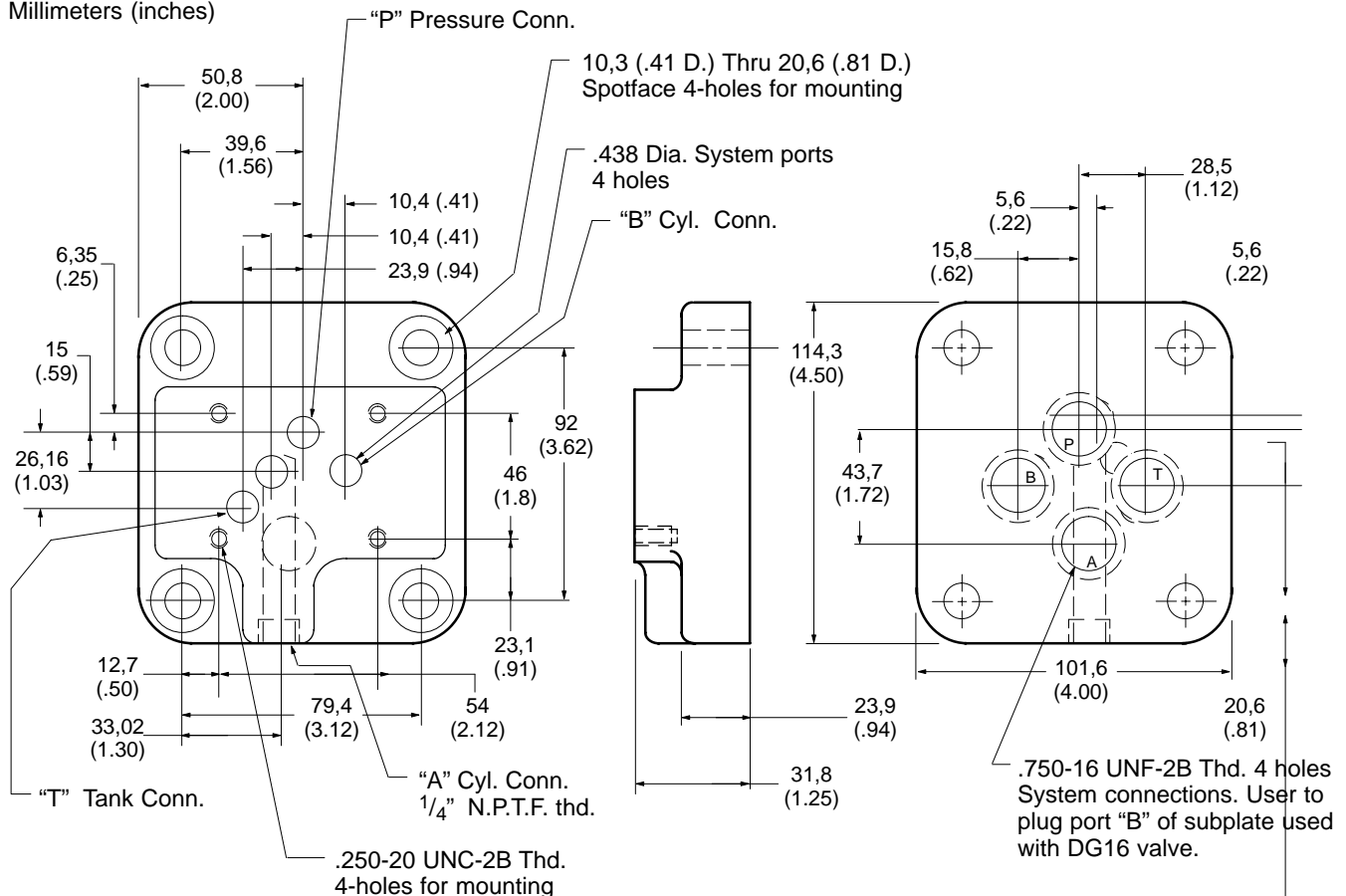

Subplates & Bolt Kits

Mounting Subplate DGSME-01-20-T8

Millimeters (inches)

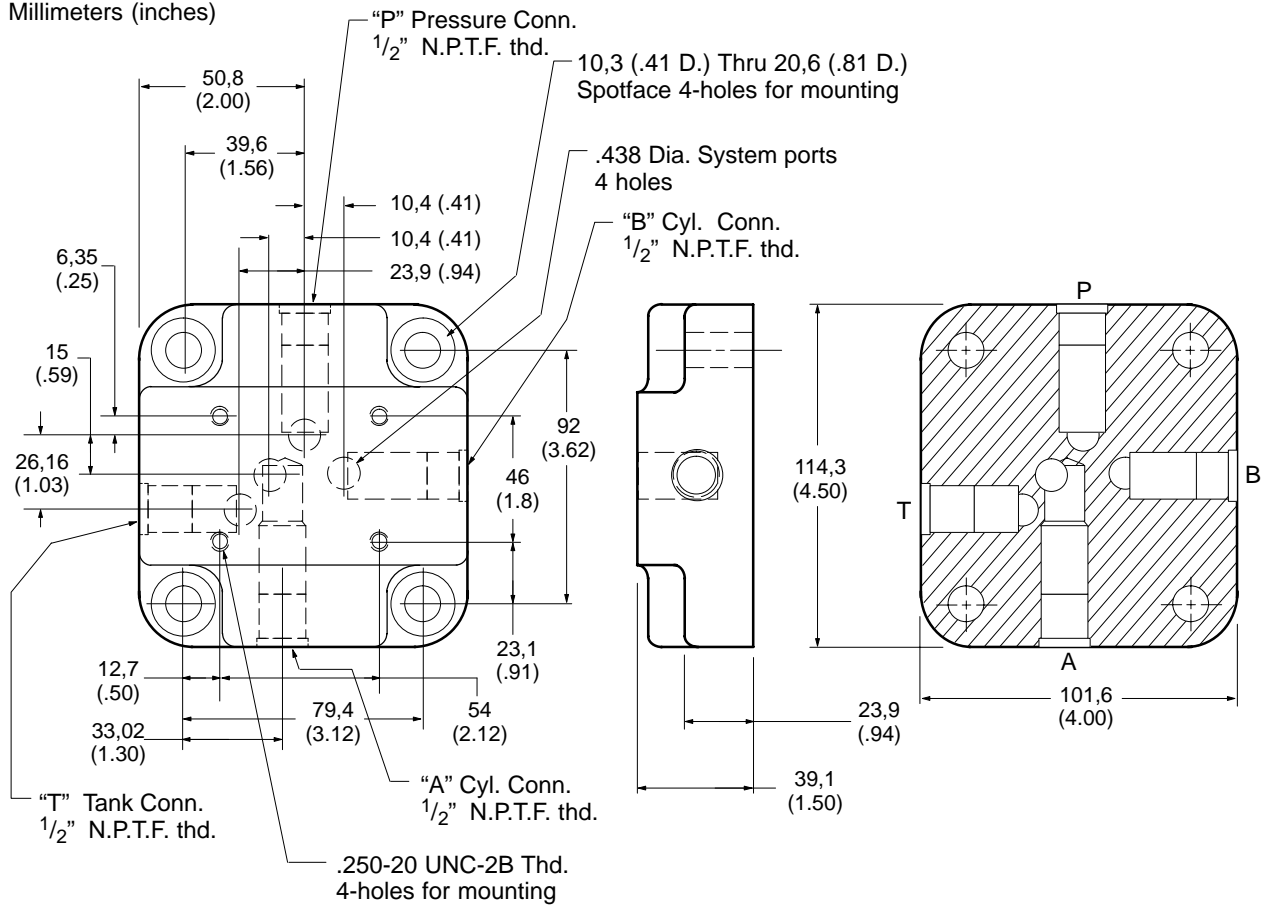

Application Data

Fluid Cleanliness

Proper fluid condition is essential for long and satisfactory life of hydraulic components and systems. Hydraulic fluid must have the correct balance of cleanliness, materials, and additives for protection against wear of components, elevated viscosity, and inclusion of air.

Essential information on the correct methods for treating hydraulic fluid is included in Vickers publication 561 "Vickers Guide to Systemic Contamination Control" available from your local Vickers distributor or by

contacting Vickers, Incorporated. Recommendations on filtration and the selection of products to control fluid condition are included in 561.

Recommended cleanliness levels, using petroleum oil under common conditions, are based on the highest fluid pressure levels in the system and are coded in the chart below. Fluids other than petroleum, severe service cycles, or temperature extremes are cause for adjustment of these cleanliness codes. See Vickers publication 561 for exact details.

Vickers products, as any components, will operate with apparent satisfaction in fluids with higher cleanliness codes than those described. Other manufacturers will often recommend levels above those specified. Experience has shown, however, that life of any hydraulic component is shortened in fluids with higher cleanliness codes than those listed below. These codes have been proven to provide a long, trouble-free service life for the products shown, regardless of the manufacturer.

Product	System Pressure Level bar (psi)		
	<70 (<1000)	70-207 (1000-3000)	207+ (3000+)
Vane Pumps – Fixed	20/18/15	19/17/14	18/16/13
Vane Pumps – Variable	18/16/14	17/15/13	
Piston Pumps – Fixed	19/17/15	18/16/14	17/15/13
Piston Pumps – Variable	18/16/14	17/15/13	16/14/12
Directional Valves	20/18/15	20/18/15	19/17/14
Pressure/Flow Control Valves	19/17/14	19/17/14	19/17/14
CMX Valves	18/16/14	18/16/14	17/15/13
Servo Valves	16/14/11	16/14/11	15/13/10
Proportional Valves	17/15/12	17/15/12	15/13/11
Cylinders	20/18/15	20/18/15	20/18/15
Vane Motors	20/18/15	19/17/14	18/16/13
Axial Piston Motors	19/17/14	18/16/13	17/15/12
Radial Piston Motors	20/18/14	19/17/13	18/16/13

Fluids and Seals

Flouorocarbon seals are standard and are suitable for use with phosphate ester type fluids or their blends, water glycol, water-in-oil emulsion fluids and petroleum oil.